

***Guide till tryck och  
gängor***

***Guide - Pressure and  
Threads***



## Tryckmätning

### Översikt över förekommande enheter inom tryckmätning

<b>MPa</b>	Mega Pascal (1 Pa = 1 N/m <sup>2</sup> )
<b>bar</b>	Bar
<b>psi</b>	pounds / square inch (1 pound = 4,45 N per kvadrattum)
<b>mVp</b>	meter vattenpelare
<b>mmHg</b>	millimeter kvicksilverpelare
<b>atm</b>	atmosfär
<b>kP/cm<sup>2</sup></b>	kiloPond / kvadratcentimeter (kallas ibland felaktigt för kilo)

### Samband mellan enheter

1 MPa = 10 bar = 145 psi = 101,97 mVp = 7500 mmHg = 9,87 atm = 10,2 kP/cm<sup>2</sup>

## Rörgångor

### Världen har idag flera olika system för rörgångor:

#### BSP (British Standard Pipe):

Används främst i Europa.  
Rak rörgång anges ISO-G följt av dimension.  
Konisk rörgång anges ISO-R följt av dimension.  
Profilvinkel: 55° Whitworth

#### NPT(F) (National Pipe Tapered (Fuel and oil))

Används främst i Nordamerika.  
Gångor av typ NPT är koniska.  
Deras raka motsvarighet kallas NPS (National Pipe Straight)  
Profilvinkel: 60°

#### Metrisk gängor

Konisk motsvarighet benämns gängtyp följt av kon.  
Profilvinkel: 60°

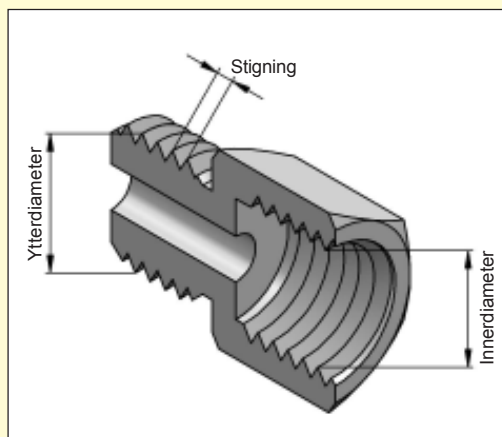

I tabellerna nedan anges måtten för de raka gängorna. De koniska gängornas diametrar skiljer sig beroende var på gängan man mäter.

### BSP-gångor

Benämning	1/8"	1/4"	3/8"	1/2"	3/4"	1"	1.1/4"	1.1/2"	2"	2.1/2"	3"
DN	06	08	10	15	20	25	32	40	50	65	80
Stigning (mm)	0,907	1,337	1,337	1,814	1,814	2,309	2,309	2,309	2,309	2,309	2,309
Ytterdiam. (mm)	9,73	13,16	16,66	20,95	26,44	33,25	41,91	47,80	59,61	75,18	87,88
Innerdiam. (mm)	8,57	11,45	14,95	18,63	24,12	30,29	38,95	44,85	56,66	72,23	84,93

### NPS-gångor

Benämning	1/8"	1/4"	3/8"	1/2"	3/4"	1"	1.1/4"	1.1/2"	2"	2.1/2"	3"
Stigning (mm)	0,941	1,411	1,411	1,814	1,814	2,209	2,209	2,209	2,209	3,175	3,175
Ytterdiam. (mm)	10,287	13,716	17,145	21,336	26,670	33,401	42,164	48,260	60,325	73,025	88,900
Innerdiam. (mm)	8,650	11,232	14,671	18,120	23,465	29,467	38,230	44,326	56,391	67,526	83,401

### Metrisk gängor

Benämning	M10	M12	M14	M16	M18	M22	M26	M27	M33	M42	M48	M60	M75
Stigning (mm)	1	1,5	1,5	1,5	1,5	1,5	1,5	2	2	2	2	2	2
Ytterdiam. (mm)	10	12	14	16	18	22	26	27	33	42	48	60	75
Innerdiam. (mm)	8,917	10,376	12,376	14,376	16,376	20,376	24,376	24,835	30,835	39,835	45,835	57,835	72,835

## Pressure units

### Overview of occurring pressure units

<b>MPa</b>	Mega Pascal (1 Pa = 1 N/m <sup>2</sup> )
<b>bar</b>	Bar
<b>psi</b>	pounds / square inch (1 pound = 4,45 N)
<b>mVp</b>	meter column of water
<b>mmHg</b>	millimeter mercury
<b>atm</b>	atmosphere
<b>kP/cm<sup>2</sup></b>	kiloPond / square centimeter

### Equivalence of units:

1 MPa = 10 bar = 145 psi = 101,97 mVp = 7500 mmHg = 9,87 atm = 10,2 kP/cm<sup>2</sup>

## Pipe Threads

There are presently different systems for pipe threads in the world:

### BSP (British Standard Pipe):

Is mainly used in Europe.

Straight pipe thread is stated ISO-G followed by dimension.

Tapered pipe thread is stated ISO-R followed by dimension.

Thread angle: 55° (Whitworth)

### NPT(F) (National Pipe Tapered (Fuel and oil))

Is mainly used in North America.

Threads of type NPT are tapered.

The corresponding straight thread is designated

NPS (National Pipe Straight)

Thread angle: 60°

### Metrical pipe thread

The corresponding tapered thread is designated thread type followed by tap.

Thread angle: 60°

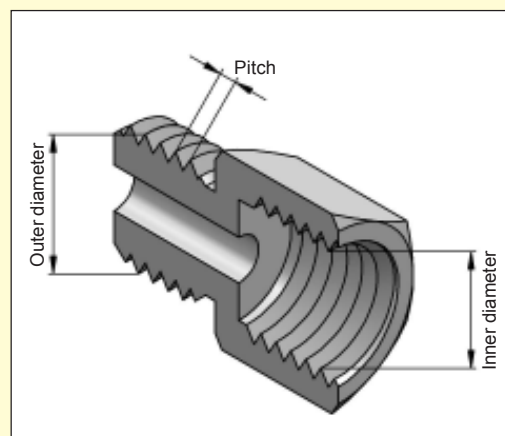

In the tables below, the dimensions of the straight threads are stated. The tapered thread diameters differs depending on where measured.

### BSP-threads

Designation	1/8"	1/4"	3/8"	1/2"	3/4"	1"	1.1/4"	1.1/2"	2"	2.1/2"	3"
DN	06	08	10	15	20	25	32	40	50	65	80
Pitch (mm)	0,907	1,337	1,337	1,814	1,814	2,309	2,309	2,309	2,309	2,309	2,309
Outer diam. (mm)	9,73	13,16	16,66	20,95	26,44	33,25	41,91	47,80	59,61	75,18	87,88
Inner diam. (mm)	8,57	11,45	14,95	18,63	24,12	30,29	38,95	44,85	56,66	72,23	84,93

### NPS-threads

Designation	1/8"	1/4"	3/8"	1/2"	3/4"	1"	1.1/4"	1.1/2"	2"	2.1/2"	3"
Pitch (mm)	0,941	1,411	1,411	1,814	1,814	2,209	2,209	2,209	2,209	3,175	3,175
Outer diam. (mm)	10,287	13,716	17,145	21,336	26,670	33,401	42,164	48,260	60,325	73,025	88,900
Inner diam. (mm)	8,650	11,232	14,671	18,120	23,465	29,467	38,230	44,326	56,391	67,526	83,401

### Metrical threads

Designation	M10	M12	M14	M16	M18	M22	M26	M27	M33	M42	M48	M60	M75
Pitch (mm)	1	1,5	1,5	1,5	1,5	1,5	1,5	2	2	2	2	2	2
Outer dia. (mm)	10	12	14	16	18	22	26	27	33	42	48	60	75
Inner dia. (mm)	8,917	10,376	12,376	14,376	16,376	20,376	24,376	24,835	30,835	39,835	45,835	57,835	72,835

